



Hoist System Owner's Manual



HYDRO MOBILE

ELEVATING
EFFICIENCY

Call us for information:
1-888-484-9376 (US)
(toll free in the United States)
450 589-8100 (Canada)



10053002-0-00000-0
Hoist_OpMan_v2.0_EN

© 2018 by Hydro Mobile, a division of AGF Access Group, Inc. All rights reserved
 This manual was produced by Hydro Mobile on Adobe® InDesign CC® version 13.1 x64 for Windows®.
 Technical drawings were prepared using Autodesk Inventor® 2017. Illustrations were created with Autodesk Inventor® 2017, Adobe® Illustrator CC® version 22.1 for Windows® and Adobe® Photoshop CC® version 19.1.5 for Windows®.
 This manual may not, in whole or in part, be copied, photocopied, reproduced, translated, or converted to any electronic or machine readable form without prior written consent of Hydro Mobile

NOTE

All assembly and operation instructions located on the hoist system take precedence over information contained in this manual. Should there be any discrepancies discovered throughout any published documentation issued by Hydro Mobile or its authorized affiliates, the following order of precedence shall prevail:

1. Written documents issued by the Hydro Mobile Engineering department
2. Recall instructions
3. Assembly or operation instructions displayed on the hoist system
4. Owner's manual

Any use of one or several Hydro Mobile hoist systems, with or without accessories, in such a configuration or manner as not explicitly described in this manual is prohibited without the prior written permission of Hydro Mobile.

Revision List

Code / Version	Date	Description
10053002-0-00000-0 V2.0	Oct 2018	First edition of owner's manual for new generation hoist system

LEGEND OF ICONS

These icons are used to highlight important information throughout this manual



Information
Useful information for safe and easy operation



Warning note
An important warning: damage or injury may occur



Useful tip
A useful tip to facilitate installation or operation



Wind speed warning
An important warning: wind speed conditions must be observed to avoid damage or injury

The information and instructions contained in this manual applies to H500 hoist systems bearing the following serial numbers

TYPE	ENGINE	BEAM
TYPE 1	HE-0051 to 0212	HB-001 to 0213
TYPE 2	HE-0216 to 0232, HE-0237	HB-0214 to 0234
TYPE 3	HE-0233 to 0236, HE-0238 to 0303	HB-0235 to 0303
TYPE 4	HE-0304 and up	HB-0304 and up



HYDRO MOBILE

www.hydro-mobile.com

125 de l'Industrie
L'Assomption, Quebec,
Canada J5W 2T9

For orders or information:
1-888-484-9376 (US)
(toll free in the United States)
450 589-8100 (Canada)

10053002-0-00000-0

GENERAL INFORMATION

Hoist system serial number	HB	
	HE	
Manufacturing date	_____	

TABLE OF CONTENTS

General Information	
Introduction	5
Warranty	6
Performance and Safety	
Performance and safety rules	7
1 - Hoist	
Overview	10
List of components included with shipped hoist system	11
Toolbox components	11
Hoist system specifications	12
Weight of components	14
Dimensions	15
Installation	15
Installation of hoist structure	16
Installation of the power pack assembly on a 24' (7,3 m) unit	17
Installation of the power pack assembly on a 14' (4,3 m) unit	18
Installation of guardrails on a 24' (7,3 m) unit	19
Installation of guardrails on a 14' (4,3 m) unit	19
Lifting operations	20
Daily verification before operation	20
Preparation and rigging of the load	20
Preparing the load	20
Rigging the load	20
Lifting the load	20
Before lifting	20
During the lift	21
After the lift	21
Lowering the load	22
Before lowering a load	22
During the lowering of a load	22
After the lowering of a load	22
Dismantling a hoist system installation	23
Safety guidelines	23
Removal of the power pack assembly	23
Removal of the hoist structure	23

2 - Safety Devices	
Safety devices	
Limit switches	24
Verification of travel limit switch and anti-two block switch	24
Fall protection	24

3 - Power Pack and Components	
Power pack and components	
Overview	
Previous generation power packs (type 1 and type 2)	25
Current generation power packs (type 3 and type 4)	25
Startup preparation instructions	26
Engine startup instructions	27
Operation of the control pendant	27
Engine shutdown instructions	28
Releasing pressure from the hydraulic circuit	28
Preparation for removal of power pack	28

4 - Transport, Storage and Maintenance	
Transport and storage	
Lifting the hoist structure – using slings or chains	29
Lifting the power pack – using slings of chains	29
Lifting the power pack – using forklift tubes	29
Storage of the hoist	30
Storage of the power pack assembly	30
Inspections and maintenance	
Inspection of the wire rope	30
Lubrication of the wire rope	31
Inspection of the hook	31
Inspection of the wedge socket	31
Greasing of the traverse chain rollers and the pivot points	31
Daily and weekly inspections and maintenance	32
Frequent inspections and maintenance	32
Annual inspections and maintenance	33
Samples of checklists	34

Introduction

Dear owner or user:

Thank you for investing in a Hydro Mobile hoist system. The design of this hoist system reflects over a decade of continued field operation, testing and research work and comes as a solution to our company's deepest concern, your safety and well being on the job.

To ensure that the workplace becomes safer and more efficient using a Hydro Mobile system, always have appropriately trained personnel assemble, operate, dismantle and move your hoist system and mast climbing work platform systems. These qualified persons will be required to read this owner's manual and assimilate the information contained herein. Failure to do so could lead to serious injury and/or equipment damage.

To maximize the life expectancy of your equipment and to enjoy years of trouble free operation, this Hydro Mobile hoist system must be serviced according to maintenance schedules and recommendations provided in this manual. It is also advised to refer to the engine user's manual included with the hoist system power pack.

Should you have any questions or concerns, please contact the nearest authorized service center or Hydro Mobile directly at 888-484-9376 (in the United States) or 450 589-8100 (in Canada). You can also visit our Web site at www.hydro-mobile.com for additional support and information on our factory safety and performance training seminars.

We wish you years and years of safe, productive construction and renovation work.

Sincerely,

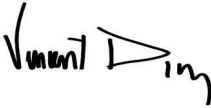
A handwritten signature in black ink that reads "Vincent Dequoy". The signature is written in a cursive style with a large, stylized "V" and "D".

Vincent Dequoy
President

Warranty

Warranty period

Hydro Mobile, a division of AGF Access Group, Inc., herein referred to as Hydro Mobile, warrants its new hoist systems to be free from defect of materials and workmanship for a period of 15 months or a maximum of 650 operating hours whichever occurs first from the date of delivery to the authorized distributor/service center.

Hydro Mobile also warrants its new hoist parts and accessories to be free from defect of materials and workmanship for a period of 15 months from the date of delivery to the authorized distributor/service center.

Product registration

In accordance with standards governing mast climbing work platform systems, the owner of a Hydro Mobile hoist system **must register the product with Hydro Mobile within sixty (60) days**. The initial buyer of a Hydro Mobile hoist system is automatically registered by Hydro Mobile.

Hydro Mobile must be kept informed of any change of ownership. The new owner must provide Hydro Mobile with a full name and address, along with the model and serial number of the hoist system acquired.

Description of warranty

Parts and accessories manufactured by Hydro Mobile

Hydro Mobile's obligation and liability under this warranty are expressly limited to repairing or replacing with re-manufactured or new parts, at Hydro Mobile's option, any part and accessory manufactured by Hydro Mobile proven defective after inspection by Hydro Mobile which appear to have been defective in material or workmanship. Only permanent repairs will be covered under this warranty. Hydro Mobile reserves the right to ask for maintenance records of the defective part before settling a claim and to deny such claim if maintenance records are not available or not compliant with maintenance schedules.

This warranty shall not apply to component parts or accessories of products not manufactured by Hydro Mobile and which carry the warranty of the manufacturer thereof or to normal maintenance (such as engine tune-up) or any part necessary to perform such maintenance. Hydro Mobile offers no other warranty, expressed or implied, and offers no warranty of merchantability or fitness for any particular purpose.

Engine

All engines manufactured by Honda under the "GX" lineup are covered by an international warranty of 36 months (12 months on mufflers). To have an engine repaired under this warranty, the engine must be brought to an authorized Hydro Mobile distributor or to an authorized Honda service center.

Battery

All the batteries shipped from the factory with new equipment are guaranteed for a period of 60 days. Any battery discharged due to operator error will not be covered under this warranty. Dead batteries that can be recharged will not be replaced under this warranty.

Costs and liability associated with warranty

Hydro Mobile's obligation under such warranty shall not include duty, taxes or any other charge whatsoever, or any liability for direct, indirect, incidental or consequential damage or delay.

Exclusion

Any use of one or several Hydro Mobile hoist systems, with or without accessories, in such a configuration or manner as not explicitly described in the owner's manual is prohibited without the prior written permission of Hydro Mobile.

Any improper use, including operation after discovery of defective or worn parts, shall void this warranty. Improper use also includes operation beyond rated capacity, substitution of parts other than those approved by Hydro Mobile, including anchor systems, or any alteration, modification or repair by others in such manner as in Hydro Mobile's judgment affects the product materially and adversely.

Labor

All warranty work must be performed by a certified Hydro Mobile technician to be eligible for reimbursement under the warranty.

Performance and Safety Rules

SAFETY comes first. The installation and operation of a hoist system on a mast climber is subject to hazards that can be avoided only by using extreme care and common sense, and by providing the **appropriate training and supervision** to all its users.

It is essential that the installation and dismantling of a hoist system and its components be carried out according to the guidelines, instructions and warnings included in the owner's manual and performed by qualified erectors/dismantlers under the supervision of a **competent person** (see boxes below).

It is also imperative that the **operation** of a hoist system be carried out according to the guidelines, instructions and warnings included in the owner's manual. To ensure safe and proper operation, Hydro Mobile hoist systems must be operated by a **qualified operator** (see box below).

Definition of the competent person

Competent person means a person who is capable of identifying existing and predictable hazards in the surroundings or working conditions which are unsanitary, hazardous or dangerous to employees, and who has authorization to take prompt corrective measures to eliminate them.

Definition of the qualified person

"**Qualified**" means a person who, by possession of a recognized degree, certificate or professional standing, or who by extensive knowledge, training and experience, has successfully demonstrated the ability to solve or resolve problems relating to the subject matter, the work or the project.

Only a **qualified person** on the specific make and model of the Hydro Mobile equipment can carry out the following tasks:

User/operator

A **qualified user/operator** is allowed to operate Hydro Mobile units according to the guidelines, instructions, warnings and methods set out in the owner's manuals and Hydro Mobile training courses and after they have been erected, tested and passed for use by a qualified person.

Erector/dismantler

A **qualified erector/dismantler** is allowed to erect, dismantle, test, pass for use and modify the configuration of Hydro Mobile units according to the guidelines, instructions, warnings and methods set out in the owner's manuals and Hydro Mobile training courses.

Technician

A **qualified technician** is allowed to perform maintenance inspections and repairs on Hydro Mobile units according to the guidelines, instructions, warnings and methods set out in the owner's manuals and Hydro Mobile training courses.

Hydro Mobile recommends that Qualified Persons follow the Hydro Mobile University Training Program on the specific task and specific make and model to get proper qualifications. For more information on Hydro Mobile University Training Programs, visit www.hydro-mobile.com/training.

General guidelines

- 1- Make sure that the motorized unit on which the hoist system is used has been installed following the installation instructions included in the owner's manual supplied with the motorized unit and that it can be operated safely.
- 2- It is recommended to use the job survey form as a guide for the proper installation of the configuration. For more information about the job survey form, refer to the owner's manual included with the motorized unit on which the hoist system will be installed.
- 3- The hoist system **must not be used** with any equipment or any accessories not specifically manufactured and rated by Hydro Mobile to be used with a hoist system. For the use and installation of any such equipment or accessories, contact the distributor/service center.
- 4- Never modify the hoist system or use substitute parts. This could adversely affect worker safety, hoist system performance and void the warranty. In addition, this could lead to serious injury or death.
- 5- Never use a hoist system in a enclosed space due to carbon monoxide emissions or in a place where explosives are stored.

Performance and Safety Rules

General guidelines (cont'd)

- 6- Contact the distributor/service center for service, repair or technical advice. Refer to equipment type and serial number when calling.
- 7- To ensure work efficiency, maintain an adequate equipment and parts inventory on the job site. Keep equipment in good condition.
- 8- The deposit of loads on a setup must be done with extreme care and under proper supervision. Loads must be distributed on all the bridges of the setup, as prescribed by the load capacities charts. Refer to the *Load Capacities* section in the owner's manual included with the motorized unit on which the hoist system is used.
- 9- **After installation, mark off the exclusion zone under and around the hoist system where loads will be handled.**

Safety guidelines before and during operation

- 1- Make sure the hoist system has been installed following the installation instructions included in this owner's manual and that it can be operated safely.
- 2- The **qualified erectors/dismantlers** in charge of the installation must make sure that the equipment being installed has been duly inspected as per the requirements of the daily, frequent or annual inspections, as applicable (see p. 30 of the *Transport, Storage and Maintenance* section for more information about inspections), and meets all applicable safety standards.
- 3- The owner of a hoist system is responsible to ensure that any person who will operate the equipment has been properly trained. The hoist system must be operated only by qualified personnel. Refer to p. 7 of this section for the definition of a qualified operator.
- 4- Qualified personnel using the hoist system must comply with any warning or instruction tag, label or plate displayed on the hoist system and the unit it is installed on. Qualified personnel must also be able to safely attach and detach loads in compliance with industry requirements and be able to communicate using recognized industry hand signals.
- 5- The qualified operator will respond only to instructions from qualified personnel. If there is a signal person, the qualified operator will respond to commands from the signal person only. **However, the qualified operator must obey a stop order at all times, no matter who gives the order.**
- 6- The qualified operator must have a firm footing and be concentrated on the task at hand when operating the hoist system.
- 7- The hoist system must be **submitted to a daily inspection before each shift** by a qualified person. For more information about daily inspections, refer to p. 30 of the *Transport, storage and maintenance* section.
- 8- Any deficiency observed must be examined by the qualified person. If the deficiency could result in unsafe working conditions, the hoist system must be **tagged out of service** and be inspected by a qualified technician.
- 9- The motorized unit **must not be raised or lowered** when the hoist system is in use.
- 10- The hoist system **must not be used to lift or move personnel.**
- 11- **A hoist system must never be used to lift loads beyond its rated capacity.** Lifting or lowering a load which is above the capacity of the hoist can result in equipment malfunction or damage and can lead to serious injury or death.
- 12- The angle of the wire rope must not exceed two degrees. To make sure the angle of the wire rope is appropriate, establish a vertical reference line by identifying where the load block falls naturally. The center of the load must not be off from that vertical reference line by more than 4" (10 cm) for every 10' (3 m) of height of lift. For example, for a height of lift of 100' (30 m), the center of the load must not be further than 40" (102 cm) away from the vertical reference line.
- 13- Loads must not be dragged. Loads **must be lifted vertically only.** The hoist system must not be used to shift a load on the ground.
- 14- Loads must not be left unattended when suspended or tied to the hook on the ground.
- 15- Loads must never be carried nor passed over people.









WARNING

The hoist system must not be used to lift or move personnel.

Performance and Safety Rules

Safety guidelines before and during operation

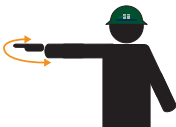
- 16- The use of appropriate fall protection equipment is **mandatory** when opening the hoist system safety access gates or whenever the worker is exposed to a fall hazard. Failure to use fall protection equipment can expose the user to serious injury or death. Refer to local regulations for more information.
- 17- It is important to make sure that the area below and around the load being hoisted remains clear and secure.
- 18- In the event of an abnormal occurrence or operation which could compromise safety or safe operation (ex. unexpected stop of the hoist, malfunction of a hoist system component, collision with an obstacle, etc.), cease all hoisting operations immediately. Take all necessary precautions and inform the competent person.
- 19- Do NOT touch any of the moving parts on the hoist system when it is in use.
- 20- The hoist system **safety access gates must be closed and locked at all times**, except when the trolley is in use. The hoist system safety access gates must be free from any material or obstruction.
- 21- The hoist system must not be used or operated during an electrical thunderstorm. The hoist system and its components must not be used as ground for electrical connections.

HAND SIGNALS	
SIGNAUX MANUELS	SÍNALES A LA MANO
 <p>RAISE MONTER LEVANTAR</p>	 <p>LOWER DESCENDRE BAJAR</p>
 <p>RAISE SLOWLY MONTER LENTEMENT LEVANTAR LENTAMENTE</p>	 <p>LOWER SLOWLY DESCENDRE LENTEMENT BAJAR LENTAMENTE</p>
 <p>EMERGENCY STOP ARRÊT D'URGENCE PARADA DE EMERGENCIA</p>	 <p>STOP ARRÊT PARADA</p>
 <p>DOG EVERYTHING PAUSE PAUSA</p>	 <p>TROLLEY CHARIOT CARETILLA</p>

Hoist System Overview

Type 4 hoist system components

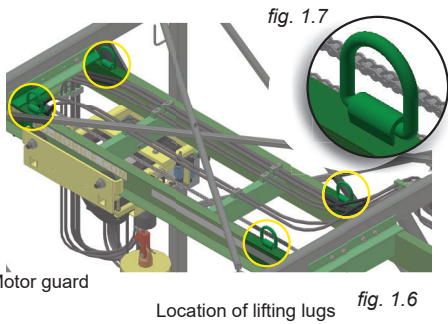
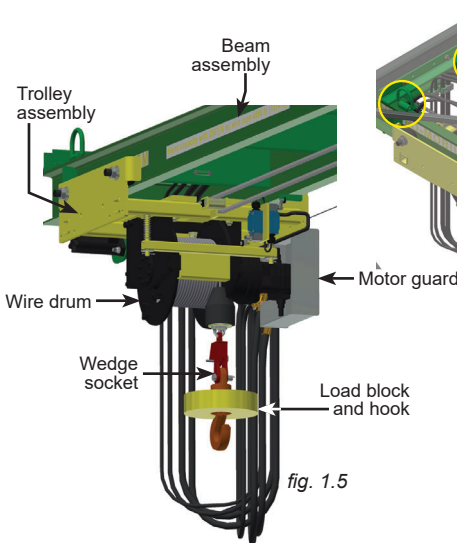
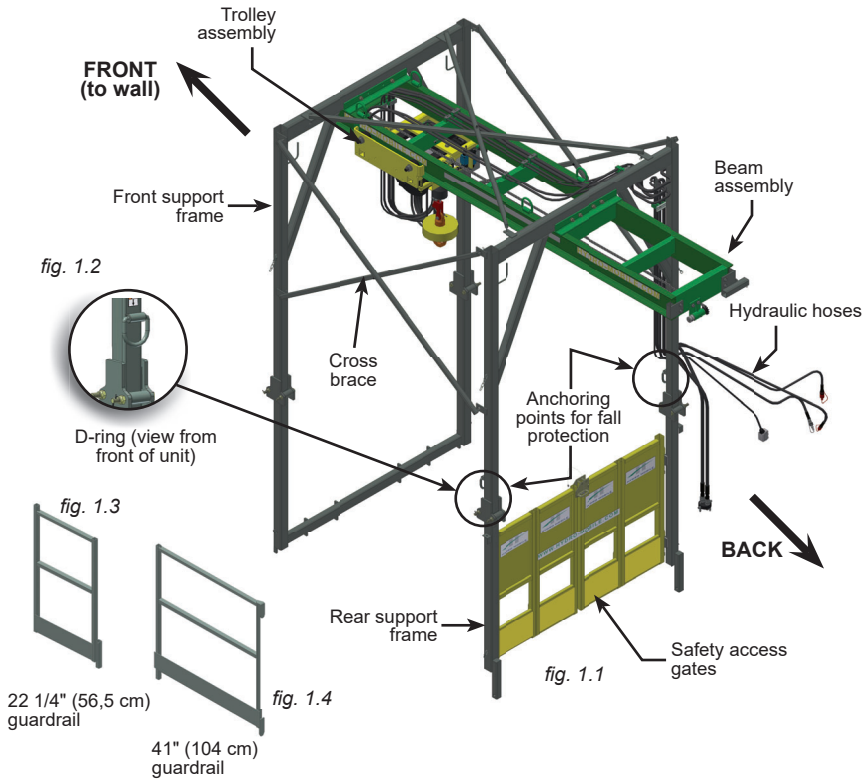

Hoist System Overview

Type 4 hoist system components

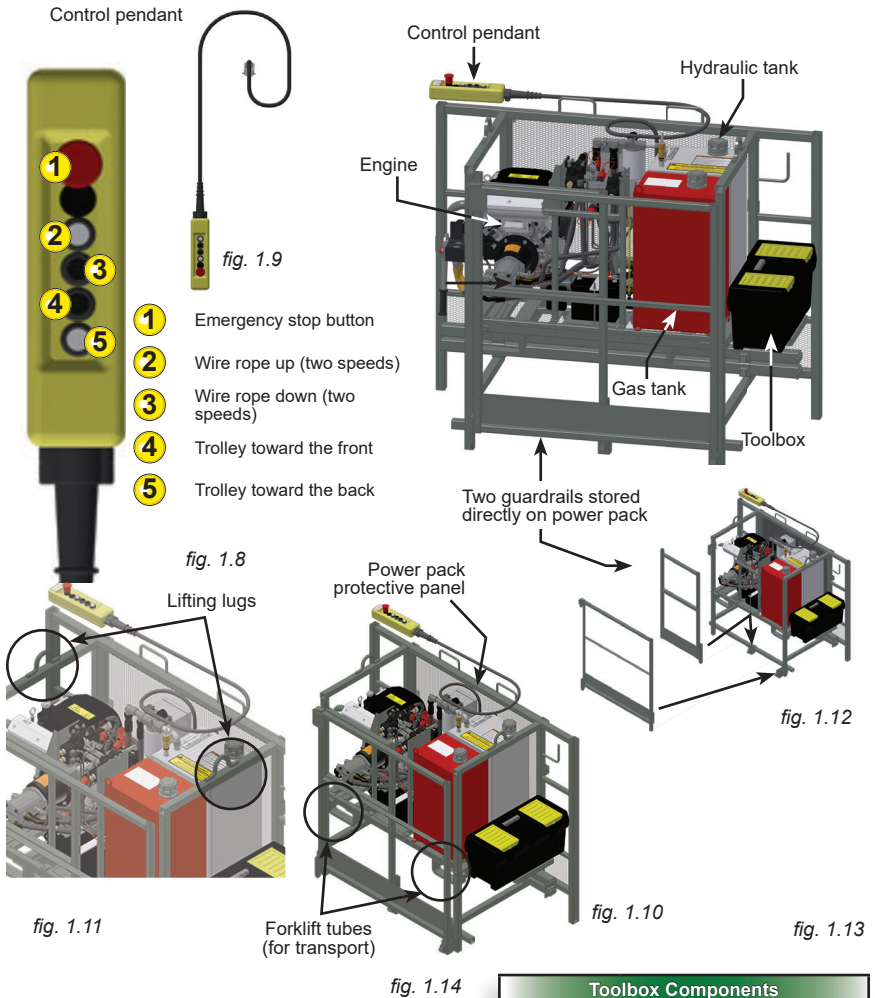

List of components included with shipped hoist system	
Qty	Component
1	hoist system assembly
1	power pack assembly including two 60" (1,5 m) outriggers
1	control pendant
1	22 1/4" (56,5 cm) guardrail
1	41" (104 cm) guardrail
Note The list of components included with each hoist system shipped may change without notice.	

Toolbox Components	
Quantity	Description
1	Owner's manual
1	Honda engine manual
4	hoist brackets
6	1/8"x2 3/4" bow tie pins
8	3/32"x1 3/4" hitch pin clips
2	3/4"x2 1/2" clevis pins
2	3/8"x2 1/2" clevis pins
3	3/16" missing links
1	ignition key
4	5/8"-11"x9" hex bolts (GR8)
6	5/8"-11" hex nuts (GR8)
6	5/8" B flat washers (SAE)
6	5/8" B lock washers (GR8)

Hoist System Specifications

fig. 1.15

General Specifications			
Dimensions of the hoist structure	As shipped	Type 1, 2 and 3	80" x 140" x 75 3/4" (W x L x H) (203 cm x 356 cm x 192 cm)
		Type 4	80" x 140" x 93 3/4" (W x L x H) (203 cm x 356 cm x 238 cm)
	When installed	Type 1, 2 and 3	80" x 135 1/4" x 125 3/4" (W x L x H) (203 cm x 344 cm x 319 cm)
		Type 4	80" x 135 1/4" x 143 3/4" (W x L x H) (203 cm x 344 cm x 319 cm)
Dimensions of the power pack	As shipped	Type 1, 2 and 3	29 1/2" x 64 1/2" x 52 1/2" (W x L x H) (75 cm x 164 cm x 133 cm)
	As shipped	Type 4	34 3/16" x 64 1/2" x 52 1/2" (W x L x H) (92 cm x 164 cm x 133 cm)
Safety device (TYPE 2, 3 and 4 hoist systems)	Anti two-block		Electric limit switch
	Trolley travel limit		Electric limit switch

fig. 1.16

Specific Features		
Wire length	250' (76,2 m)	350' (106,7 m)
Weight of beam with support frames	1960 lb (889 kg)	2000 lb (907 kg)
Weight of power pack assembly with guardrails	810 lb (107 kg)	810 lb (107 kg)
Maximum load capacity	4000 lb (1814 kg)	3600 lb (1633 kg)
Vertical travel speed	Average of 60' (18,3 m)/minute	Average of 60' (18,3 m)/minute

fig. 1.17

Hydraulic Specifications	
Component	Specifications
Double gear pump	2 x 6.23 US GPM (23,58 l/min)
Hydraulic tank capacity	14 US gal (52,99 l)
Hydraulic oil	Dextron III ATF
Oil filter	Ikron filter model HE K44-20-135-AS-SP010 (HM part number A0410000-0004)



WARNING

It is mandatory to refer to the owner's manual included with the motorized unit on which this hoist is used for specifications regarding the limitations imposed by wind speeds.

Hoist System Specifications

fig. 1.18

Engine Specifications			
Hoist type	Type 1	Type 2	Type 3 and Type 4
Model	Honda GX670	Honda GX690	Honda GX630
Rated power	20.5 HP @ 3600 rpm	22.1 HP @ 3600 rpm	20.8 HP @ 3600 rpm
Fuel consumption	2.11 G/hr (8 l/hr)	1.77 G/hr (6.7 l/hr)	1.56 G/hr (6 l/hr)
Spark plug	ZFR5A (NGK)	ZFR5F (NGK)	ZFR5F (NGK)
Oil type	SAE 10W-30	SAE 10W-30	SAE 10W-30
Gasoline tank capacity	14 US gal (52,99 l)	14 US gal (52,99 l)	14 US gal (52,99 l)
Oil capacity	1,5 US qt (1,40 l)	1,8 US qt (1,70 l)	1,8 US qt (1,70 l)
Charging system	12 VDC - 20 ampere-hour	12 VDC - 17 ampere-hour	12 VDC - 17 ampere-hour
Battery	12 VDC	12 VDC	12 VDC
For any other information regarding the use and the maintenance of Honda engines, refer to the Honda user's manual			

fig. 1.19

Winch Specifications		
Hoist type	Type 1 and Type 2	Type 3 and Type 4
Winch model	Pullmaster M5-3-222-B	Dinamic Oil A62 OM580
Gear box oil quantity	0.8 US gal (3 l)	0.4 US gal (1,5 l)
Gear box oil type	SAE 90	ISO VG150
Brake type – parking	Wet clutch, spring-applied / pressure-released	Wet clutch, spring-applied / pressure-released
Brake type – dynamic	Wet clutch, spring-applied / pressure-controlled (with oil cooler)	Hydraulic brake valve

fig. 1.20

Lifting Wire Rope Specifications		
Cable length	250' (76,2 m)	350' (106,7 m)
Cable diameter	10 mm	10 mm
Cable length	290' (88,4 m)	390' (118,9 m)
Minimum breaking force of wire rope	22,000 lbf (9979 kg force)	22,000 lbf (9979 kg force)
Cable type	35x7 compacted, non-rotating	35x7 compacted, non-rotating
Wire rope lay	Right	Right
Minimum dead wraps around drum	5	5

Hoist System Specifications

Weight of Components			
HOIST SYSTEM and components		GUARDRAILS and OUTRIGGERS	
Description	Weight	Description	Weight
Hoist system complete assembly (including support frames and power pack)	2770 lb (1256 kg)	22 1/4" (57 cm) guardrail	25 lb (11 kg)
Hoist beam assembly (including support frames, as shipped)	1960 lb (889 kg)	41" (104 cm) guardrail	35 lb (16 kg)
Front support frame assembly	330 lb (206 kg)	60" (1,5 m) outrigger	15,6 lb (7 kg)
Rear support frame assembly (with access gates)	455 lb (206 kg)		
Cross brace	25 lb (11 kg)		
Power pack assembly (including support structure)	810 lb (107 kg)		
Control pendant	8 lb (3,6 kg)		
ACCESSORIES			
Description	Weight		
Adapter bracket for 14' (4,3 m) unit	31 lb (14 kg)		

Dimensions of the Hoist Installation

Note: Hoist system shown as installed on an M2 Series 24' (7,3 m) motorized unit

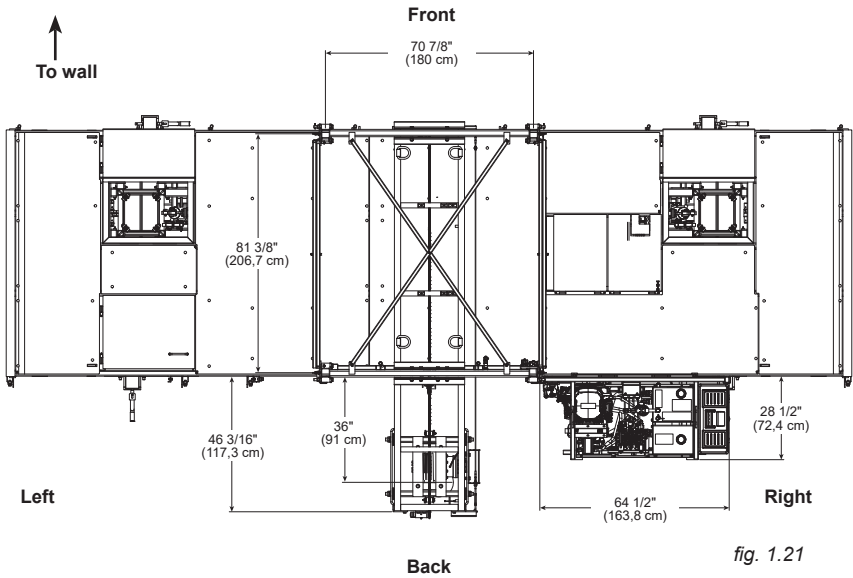

fig. 1.21

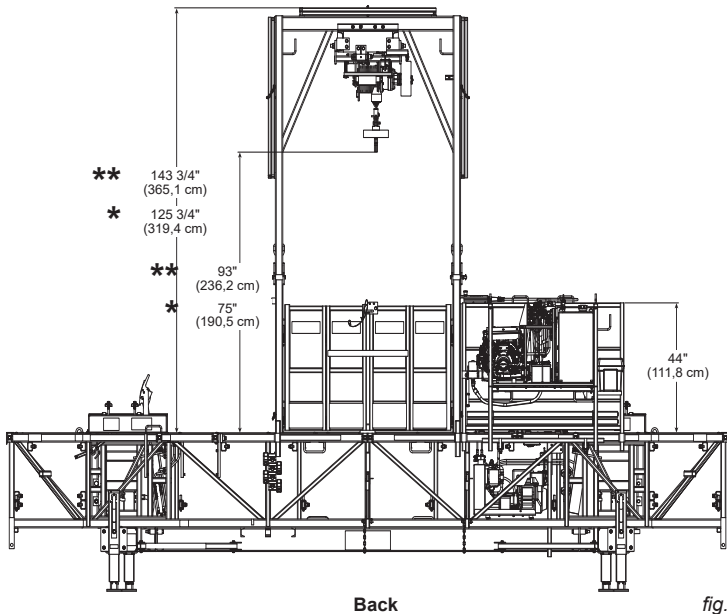

fig. 1.22

* Type 1, 2 and 3 hoist support frame

** Type 4 hoist support frame

Installation

The hoist can be installed on both the 24' (7,3 m) and 14' (4,3 m) models of M2 Series motorized units. The installation of the hoist on the M2 Series 14' (4,3 m) motorized unit will require the use of an optional adapter bracket to install the power pack assembly.

The installation of the hoist must be carried out by qualified erectors/dismantlers under the supervision of a competent person, in accordance with all applicable local regulations.

Installation of the hoist structure

- 1- Make sure that there are no guardrails installed on the unit (fig. 1.23).
- 2- Secure chains or slings to the lifting lugs on top the hoist structure (fig. 1.6, p. 10). For more information about the lifting of the hoist structure, refer to p. 16 of the *Transport, Storage and Maintenance* section.
- 3- Lift the hoist structure by about 6" (15 cm).
- 4- **Holding the hoist structure**, unhook the chains to unfold the bottom half of the front and back support frames of the structure (see fig. 1.24 and fig. 1.25).
- 5- Lift the structure enough to straighten both support frames. Secure each in place with the supplied 5/8" x 4 1/2" (GR8) bolt assemblies. Tighten all bolt assemblies to a torque of 120 lb-ft (163 N-m), as shown in fig. 1.26.

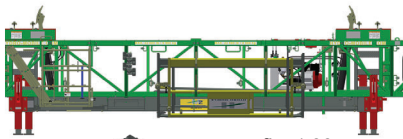

fig. 1.23

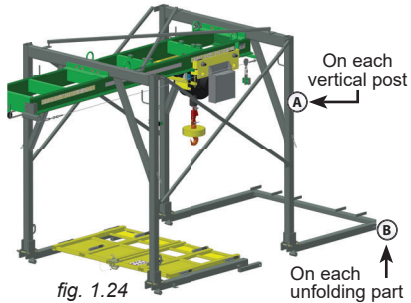

fig. 1.24

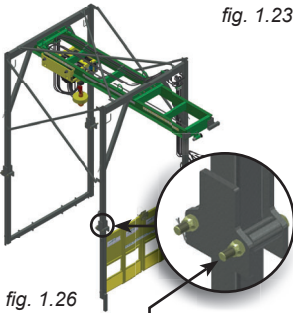

fig. 1.26

fig. 1.27

Secure each leg with bolt assembly



fig. 1.25

- 6- Align the hoist structure over the area on the unit where it will be installed (centered on the unit).
- 7- Carefully **lower and hold** the hoist structure into position, inserting the legs of the rear support frame assembly in the hoist pockets located on the back of the motorized unit. Secure the support frame in place with 3/4" x 2 1/2" clevis pins and bow tie clips (fig. 1.29).

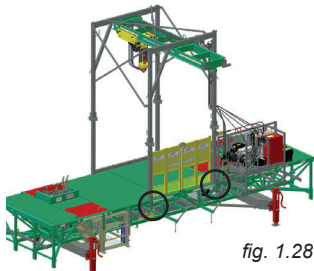

fig. 1.28

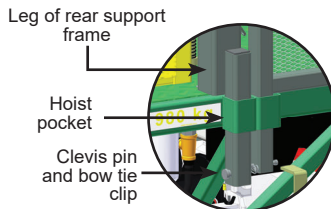
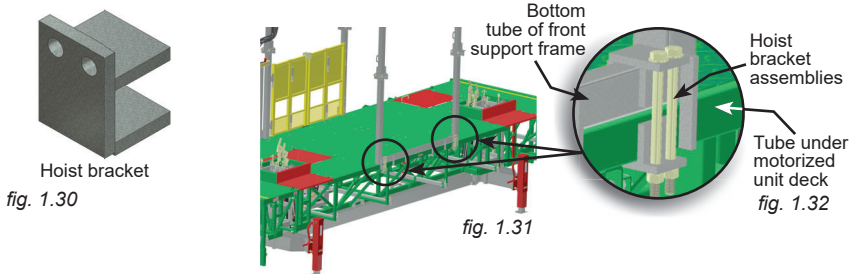

fig. 1.29

Installation

Installation of the hoist structure (cont'd)

- 8- **Continue to hold the hoist structure** and retrieve the hoist brackets from the toolbox (fig. 1.30). Clamp a bracket on the bottom tube at one end of the front support frame of the hoist structure. Clamp another bracket to the tube under the motorized unit deck. Secure both plates together with 5/8" X 9" (GR8) bolt assemblies tightened to a torque of 120 lb-ft (163 N-m).



- 9- Repeat step 8 to secure the other end of the support frame. Release the hoist structure.
- 10- Proceed with the installation of the power pack, following the guidelines hereafter that are appropriate for the unit model on which the hoist system is installed.

Installation of the power pack assembly on an M2 Series 24' (7,3 m) unit

- 1- Insert the outriggers of the power pack assembly into the outrigger pockets on the unit (fig. 1.33) until they are protruding from the unit by about 30" (76 cm).
- 2- Secure slings to the lifting lugs on top of the power pack assembly (fig. 1.6, p. 10). For more information about the lifting of the power pack assembly, refer to p. 29 of the *Transport, Storage and Maintenance* section.
- 3- Lift the power pack and slide the legs of the support structure into the vertical pockets welded on the rear edge of the motorized unit structure ("A" and "B" in fig. 1.34).
- 4- **Continue to hold the power pack** and push in the outriggers until each stop plate is snug against the power pack support structure ("C" in fig. 1.34). Make sure the rack sits squarely on the outriggers (fig. 1.33). Secure the outriggers in place by tightening the pocket bolts at 30 lb-ft (41 N-m).
- 5- Release the power pack.
- 6- Refer to the *Power Pack and Components* section on p. 25 for instructions on the connection of hydraulic components, the limit switch harness and the control pendant.

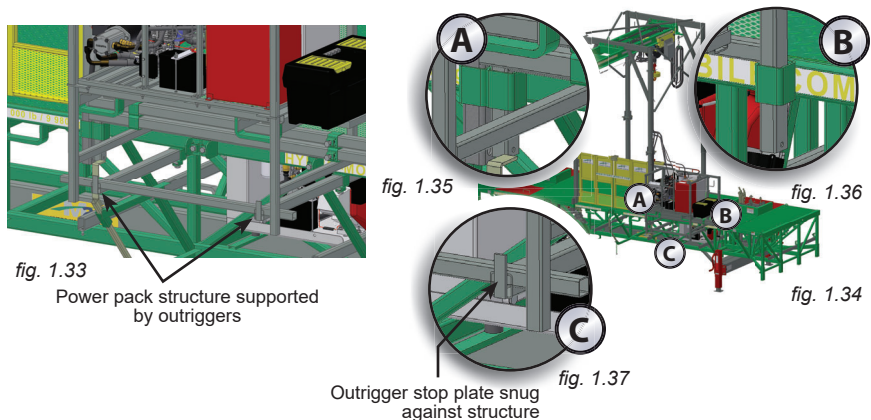

Installation

Installation of the power pack assembly on an M2 Series 14' (4,3 m) unit

The installation of the hoist power pack on a 14' (4,3 m) motorized unit requires the use of an optional power pack adapter.

- 1- Hold the power pack adapter so that the pockets located at the bottom of the bracket line up with the outrigger pockets on the motorized unit. Make sure the bracket is positioned properly, with the lock bolts facing outwards, as shown in fig. 1.44.
- 2- Slide the outriggers through the pockets on the adapter and into the outrigger pockets until they are protruding from the unit by about 34" (86 cm).
- 3- Secure slings to the lifting lugs on top of the power pack assembly (fig. 1.6, p. 108).
- 4- Using a rough terrain forklift or a crane, lift the power pack and slide the back legs into the vertical pockets of the rack adapter (fig. 1.42).
- 5- **Still holding the power pack**, push in the outriggers until the stop plates are snug against the power pack support structure (fig. 1.45). Make sure the power pack sits squarely on the outriggers.
- 6- Secure the outriggers in place by tightening the pocket bolts at 30 lb-ft (41 N-m).
- 7- Secure the power pack in place by tightening the bolt on each vertical pocket on the adapter to a torque of 30 lb-ft (41 N-m).
- 8- Release the power pack.
- 9- Refer to the *Power Pack and Components* section on p. 25 for instructions on the connection of hydraulic components, the limit switch harness and the control pendant.

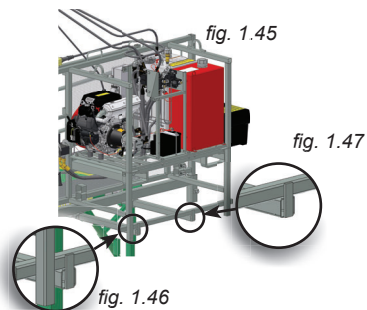
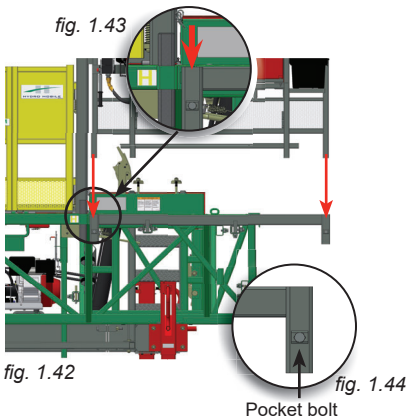
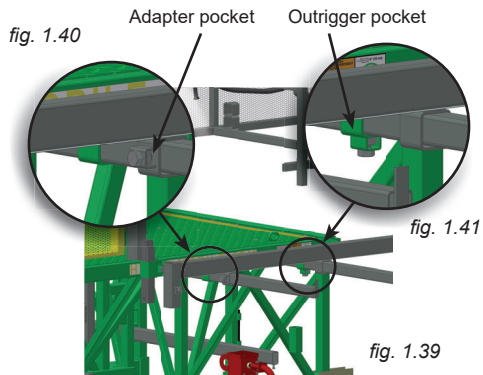
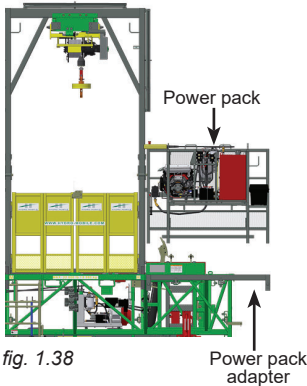

Installation

Installation of guardrails on a 24' (7,3 m) motorized unit

The installation of the hoist system on a 24' (7,3 m) motorized unit requires the use of the 22 1/4" (57 cm) and the 41" (104 cm) hoist guardrails included with the power pack assembly.

- 1- Make sure that the hoist and the power pack have been installed properly.
- 2- Install the 84" (213 cm) door support guardrail ("1" in fig. 1.48) at the left end of the motorized unit. Secure the guardrail by tightening each pocket bolt to a torque of 30 lb-ft (41 N-m).
- 3- Lift and hold the clevis pin on the welded tab on the support frame (fig. 1.50). Install the 22 1/4" (57 cm) hoist guardrail ("2" in fig. 1.48) between the door guardrail and the hoist support structure. Make sure that the vertical tube of the guardrail is snug under the welded tab on the support frame. To secure the guardrail, release the clevis pin and make sure it falls back through the hole in the welded tab and inside the top vertical tube of the guardrail (fig. 1.50). Tighten the pocket bolt at the other end of the guardrail (fig. 1.51) to a torque of 30 lb-ft (41 N-m).

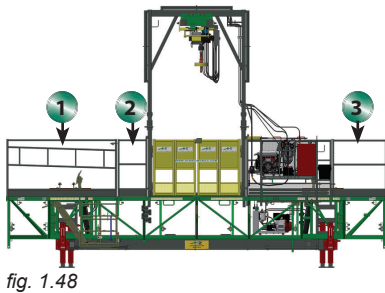

fig. 1.48

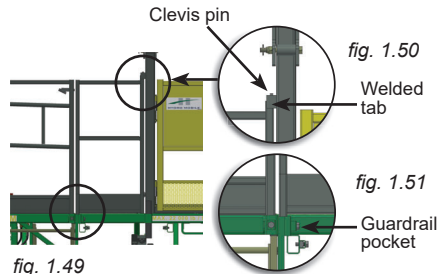

fig. 1.49

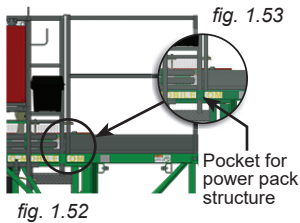

fig. 1.52

fig. 1.53

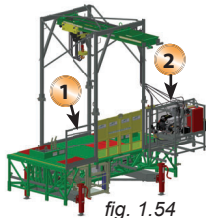

fig. 1.54

Guardrail installed in front of power pack protective panel

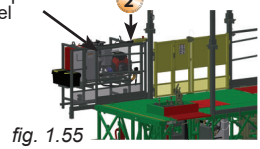

fig. 1.55

- 4- Insert the tab of the 41" (104 cm) guardrail in the pocket holding the power pack structure in place on the right end of the motorized unit. Secure the guardrail in place by tightening the bolt on the pocket to a torque of 30 lb-ft (41 N-m).

Installation of guardrails on a 14' (7,3 m) motorized unit

- 1- Make sure the hoist and the power pack have been installed properly.
- 2- Install the 44" (112 cm) door support guardrail at the left end of the motorized unit ("1" in fig. 1.54). Secure the guardrail in place by tightening the bolt on each guardrail pocket to a torque of 30 lb-ft (41 N-m).
- 3- Install the 44" (112 cm) door support guardrail at the right end of the motorized unit ("2" in fig. 1.54), in front of protective panel of the power pack assembly, as shown in fig. 1.55). Secure the guardrail in place by tightening the bolt on each guardrail pocket to a torque of 30 lb-ft (41 N-m).

Lifting Operations

Daily Verification

Daily verification before operation

- 1- Before using the hoist system, perform every step in the daily inspection checklist. Refer to p. 34 of the *Transport, Storage and Maintenance* section for more information about the daily inspection checklist.
- 2- If the hoist is a new addition on the setup, it is recommended to fill out the handover sheet each time the setup is modified. For more information about the handover sheet, refer to the owner's manual included with the motorized unit used for the installation.

Preparation and Rigging of the Load

Preparing the load

- 1- Make sure that the load to be lifted does not exceed the rated load capacities of the installation when combined with the weight of the hoist system and the rigging equipment.
- 2- Make sure that the center of gravity of the load is in line with the center of the hoist. The load must be lifted vertically, without any side pull.
- 3- Make sure that the load to be lifted is balanced.

Rigging the load

- 1- Identify the lifting points.
- 2- Choose a rigging equipment that is appropriate for the load to be lifted.
- 3- Inspect the rigging equipment (slings, rope, chains, hooks, shackles) and make sure it is in good condition.

Lifting the Load

SAFETY comes first. All lifting operations must be performed by a qualified operator. For the definition of a qualified operator, refer to p. 7 of the *Performance and Safety Rules* section.

The qualified operator will respond only to instructions from qualified personnel. If there is a signal person, the qualified operator will respond to commands from the signal person only. **However, the qualified operator must obey a stop order at all times, no matter who gives the order.**

It is mandatory to make sure the weather conditions and the wind speeds are appropriate before operating the hoist. Refer to the owner's manual included with the motorized unit on which the hoist is installed for information about exposure to wind and weather.

Before lifting

- 1- It is mandatory to make sure that the motorized unit is properly positioned along the mast before using the hoist. Refer to the owner's manual included with the unit on which the hoist is installed for information about tie schedules and restrictions.
- 2- Make sure that the load has been prepared and rigged as described in the preparation and rigging instructions above.
- 3- Inspect the load and make sure that there is no loose part or component that could fall during the lift, including debris on the surface of the load.
- 4- Make sure that the control pendant is clean and working properly.
- 5- Make sure that the hoist wire rope is wound properly. If not, unwind the wire rope and rewind it slowly.
- 6- On a hoist equipped with limit switches, make sure that the trolley limit switch and the anti two-block switch are in place and are working properly. Refer to p. 24 of the *Safety Devices* section for more information on limit switches.

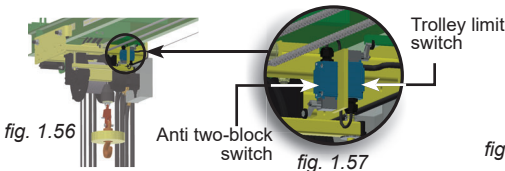

fig. 1.56

fig. 1.57



fig. 1.58

fig. 1.59

Lifting Operations

Lifting the Load

Before lifting (cont')

- 7- Make sure that the path of travel of the load is free of obstruction and that the angle of the wire rope is under 2 degrees. To make sure the angle of the wire rope is appropriate, establish a vertical reference line by identifying where the load block falls naturally. The center of the load must not be off from that vertical reference line by more than 4" (10 cm) for every 10' (3 m) of height of lift. For example, for a height of lift of 100' (30 m), the center of the load must not be further than 40" (102 cm) away from the vertical reference line.
- 8- Make sure that all unauthorized personnel remains outside of the lifting zone. **The load must not be raised or lowered when personnel are below the load.**

During the lift

- 1- Make sure that no one is riding on the load during the lift.
- 2- Make sure throughout the lifting operation that the area under the load remains clear of people.
- 3- Using the UP button on the control pendant at **first speed**, raise the load slowly until the wire rope is taut. For instructions on the use of the control pendant, refer to p. 27 of the *Power Pack and Components* section.
- 4- Lift the load at **first speed** by a few inches (centimeters) and make sure that the load is balanced, secured and properly positioned on the hook.
- 5- Proceed with the lifting of the load at **second speed**. Avoid sudden acceleration or deceleration and lift the load vertically, without side pulls.
- 6- When the load is close to the platform, release the UP button halfway to switch to **first speed** and monitor the lifting carefully to avoid any contact with the platform, the hoist power pack or the beam assembly.
- 7- Once the load has reached the platform, release the UP button.
- 8- Lower the throttle control lever to slow down the engine (fig. 3.20, p. 27).

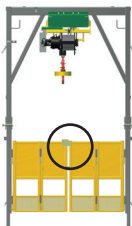

fig. 1.60

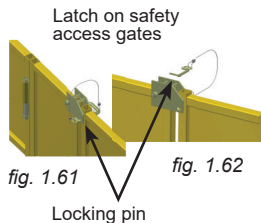
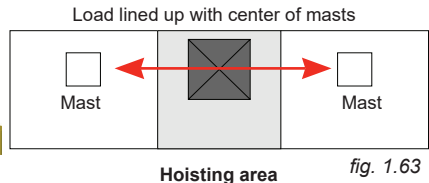

fig. 1.61

fig. 1.62

Locking pin



Hoisting area

fig. 1.63

- 9- The qualified operator must make sure to be tied to an authorized fall protection tie point and must ensure that other personnel on the platform are a minimum of 6' (1,8 m) away from the open area before opening the safety access gates (see fig. 2.4, p. 24).
- 10- Remove the pin to release the latch and open the safety access gates.
- 11- Using the trolley, move in the load over the platform. It is important to line up the load with the center of the masts as much as possible to avoid shifting the balance of the platform, as shown in fig. 1.63.
- 12- Once in position, carefully lower the load at **first speed**.

After the lift

- 1- Once the load has been deposited on the platform, close the safety access gates and secure. **The safety access gates must be kept closed and locked at all times**, except when the trolley is in use.
- 2- Do NOT use the hoist to pull on the rigging equipment to remove it from under the deposited load.

Lifting Operations

Lowering the Load

SAFETY comes first. All lifting operations must be performed by a qualified operator. For the definition of a qualified operator, refer to p. 7 of the *Performance and Safety Rules* section.

The qualified operator will respond only to instructions from qualified personnel. If there is a signal person, the qualified operator will respond to commands from the signal person only. **However, the qualified operator must obey a stop order at all times, no matter who gives the order.**

It is mandatory to make sure the weather conditions and the wind speeds are appropriate before operating the hoist. Refer to the owner's manual included with the motorized unit on which the hoist system is installed for information about exposure to wind and weather.

Before lowering a load

- 1- It is mandatory to make sure that the motorized unit is properly positioned along the mast before using the hoist. Refer to the owner's manual included with the unit on which the hoist system is installed for information about tie schedules and restrictions.
- 2- Make sure that the load has been prepared and rigged as described in the preparation and rigging instructions on p. 20.
- 3- Inspect the load and make sure that there is no loose part or component that could fall during the lift, including debris on the surface of the load.
- 4- Make sure that the control pendant is clean and working properly.
- 5- Make sure that the hoist wire rope is wound properly. If not, unwind the wire rope and rewind it slowly.
- 6- On a hoist system equipped with limit switches, make sure that the trolley limit switch and the anti two-block switch are in place and are working properly. Refer to p. 24 of the *Safety Devices* section for more information on limit switches.
- 7- Make sure that the path of travel of the load is free of obstruction and that the angle of the wire rope is under 2 degrees. Establish a vertical reference line by identifying where the load block falls naturally. The center of the load must not be off from that vertical reference line by more than 4" (10 cm) for every 10' (3 m) of height of lift. For example, for a height of lift of 100' (30 m), the center of the load must not be further than 40" (102 cm) away from the vertical reference line.
- 8- Make sure that all unauthorized personnel remains outside of the lowering zone. **The load must not be raised or lowered when personnel are below the load.**

During the lowering of a load

- 1- Make sure that no one is riding on the load while it is being lowered.
- 2- Make sure throughout the lowering operation that the area under the load remains clear of people.
- 3- Lower the throttle control lever to slow down the engine.
- 4- Using the UP button on the control pendant at **first speed**, raise the load slowly until the wire rope is taut. For instructions on the use of the control pendant, refer to p. 27 of the *Power Pack and Components* section.
- 5- Lift the load off the platform at **first speed** by a few inches (centimeters) and make sure that the load is balanced, secured and properly positioned on the hook.
- 6- The qualified operator must make sure to be tied to an authorized fall protection tie point and must ensure that other personnel on the platform are a minimum of 6' (1,8 m) away from the open area before opening the safety access gates (see fig. 2.4, p. 24)
- 7- Remove the pin to release the latch and open the safety access gates.
- 8- Using the trolley, move the load out beyond the platform.
- 9- Once the load is off the platform, close the safety gates and secure. **The safety gates must be kept closed and locked at all times**, except when the trolley is in use.
- 10- Lift the throttle control lever to reach maximum throttle on the engine (fig. 3.20, p. 27).
- 11- Using the DOWN button, proceed with the lowering of the load at **second speed**. Avoid sudden acceleration or deceleration when lowering the load.
- 12- When the load is close to the ground, release the DOWN button halfway to switch to **first speed** and make sure someone is on the ground to monitor the lowering of the load.

After the lowering of a load

- 1- Once the load has been deposited on the ground, release the DOWN button.
- 2- Unhook the load and raise the hook high enough to make sure no load can be attached to it.
- 3- Do NOT use the hoist to pull on the rigging equipment to remove it from under the deposited load.

Dismantling a hoist installation

SAFETY comes first. It is essential that the **dismantling** of a hoist system be carried out by **qualified erectors/dismantlers** under the supervision of a **competent person** and be performed with the same care and precaution taken during the installation. It is mandatory to make sure that the hoist installation remains stable and secure throughout the dismantling operations. For the definition of a qualified erector/dismantler, refer to p. 7 of the *Performance and Safety* section.



Safety guidelines

- 1- Make sure that all the equipment necessary for the safe dismantle of the hoist installation is on hand (slings, crane or rough terrain forklift, etc., as required).
- 2- Make sure that the motorized unit on which the hoist is installed is at base level.
- 3- Make sure that the hoist safety access gates are closed and latched securely.
- 4- Make sure that the wire rope is rewound completely and properly.
- 5- Move the trolley so it is centered between the front and the rear support frames.
- 6- Prepare the power pack assembly and the hydraulic components as described in the instructions on p. 28 of the *Power Pack and Components* section.
- 7- If the hoist was used on a 24' (7,3 m) motorized unit, remove the hoist guardrails from the unit and store them on the power pack support structure.

Removal of the power pack assembly

- 1- Prepare the hoist installation as described in the safety guidelines above.
- 2- If the hoist is installed on an M2 Series 14' (4,3 m) motorized unit, loosen the bolts securing the power pack support structure to the adapter.
- 3- Secure slings to the lifting lugs on top of the power pack assembly. For more information about the lifting of the power pack assembly, refer to p. 29 of the *Transport, Storage and Maintenance* section.
- 4- Using a rough terrain forklift or a crane, hold the power pack assembly.
- 5- Lift the power pack and store it properly.
- 6- Loosen the outrigger pocket bolts and remove the outriggers. Store the outriggers properly. If the power pack was installed on a 14' (4,3 m) unit, remove and store the adapter.

Removal of the hoist structure

- 1- Secure chains or slings to the lifting lugs on top of the hoist structure. For more information about the lifting of the hoist structure, refer to p. 29 of the *Transport, Storage and Maintenance* section.
- 2- Using a rough terrain forklift or a crane, hold the hoist structure.
- 3- Remove the hoist bracket assemblies securing the front support frame on the motorized unit. Store the bracket assemblies properly.
- 4- Remove the clevis pin assembly on each leg of the rear support frame (see "1" in fig. 1.64). Store the pin assemblies properly.
- 5- On each leg of both support frames (front and rear), remove the bolt assembly that does not have a cotter pin (see "2" in fig. 1.64).
- 6- Lift the hoist structure off the platform and lower it carefully on the ground so the support frames will fold at 90°, as shown in fig. 1.67.
- 7- Fold each support frame and secure each in place with the chain (fig. 1.24 and fig. 1.25, p. 16). Put the bolt assemblies removed in step 5 back into place and tighten slightly.
- 8- Lift the hoist structure and store it appropriately. For more information about storing a hoist structure, refer to p. 30 of the *Transport, Storage and Maintenance* section.

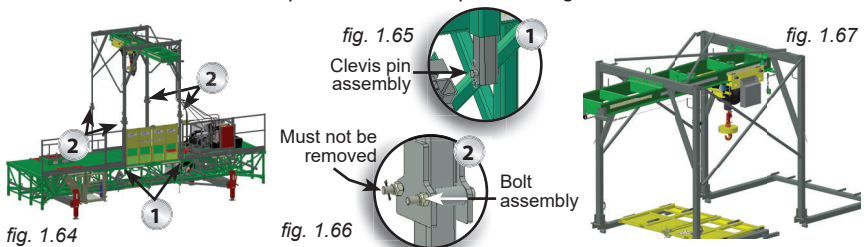

Safety Devices

Limit switches

Some models of the H500 hoist trolley (TYPE 2, 3 and 4) are equipped with a travel limit switch to control travel along the beam (fig. 2.2).

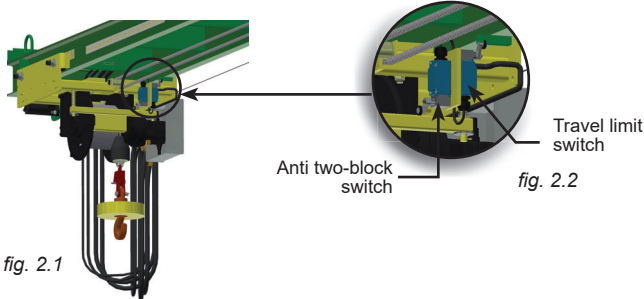

fig. 2.1

Some models of the H500 hoist (TYPE 2, 3 and 4) are also equipped with an anti two-block switch to prevent the load block assembly from coming into contact with the winch drum and interfering with the safe operation of the hoist (fig. 2.2).

Verification of the travel limit switch and the anti two-block switch

- 1- Lower the throttle control lever to slow down the engine.
- 2- Test the operation of the travel limit switch by moving the trolley out toward the rear of the motorized unit and back toward the front of the unit. If the limit switch is working properly, the trolley will stop before reaching the end of the beam at each end.
- 3- With the load block assembly out over the rear of the motorized unit, test the operation of the anti two-block switch by lowering the rope and raising it back again at first speed. If the switch is working properly, the load block will stop before reaching the winch drum.
- 4- If any of the switches is not working properly, the hoist must be put out of service until it has been inspected and repaired by a qualified technician. For the definition of a qualified technician, refer to p. 7 of the *Performance and Safety* section.

Fall Protection

The use of fall protection equipment is **mandatory** when opening the safety access gates. It is recommended to use a combination of full body harness and a shock-absorbing lanyard. It is mandatory to use certified fall protection equipment that is clean and in good working condition. Fall protection equipment must be inspected before each use and be replaced if found or suspected to be defective. Refer to the manufacturer's recommendations for more information about the use and care of the selected equipment. Refer also to local regulations for more information about fall protection equipment requirements.

- 1- Using one of the designated tie points (D-ring) on the hoist structure, secure the fall protection equipment. Tie points are designed to be used by a worker to tie himself to the unit (not more than one worker per hoist system installation).
- 2- Remove the pin to release the latch and open the safety access gates.
- 3- Make sure that the safety access gates are closed and secured when the trolley is not in use. The safety gates must be kept closed and locked at all times, except when the trolley is in use.

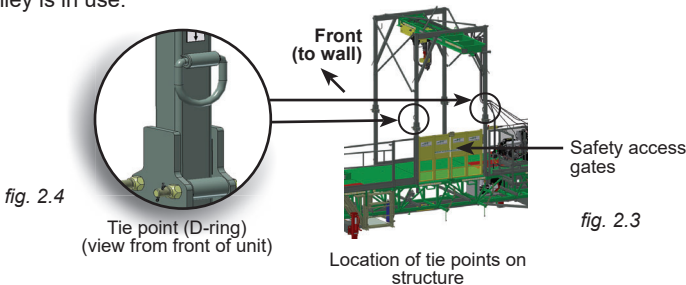

fig. 2.4

Tie point (D-ring)
(view from front of unit)

fig. 2.3

Location of tie points on
structure

Power Pack and Components

Overview

Previous generation power packs (type 1 and type 2)

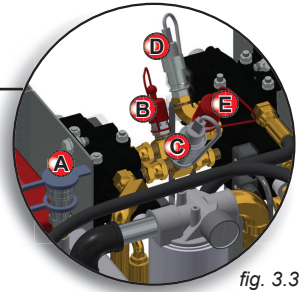
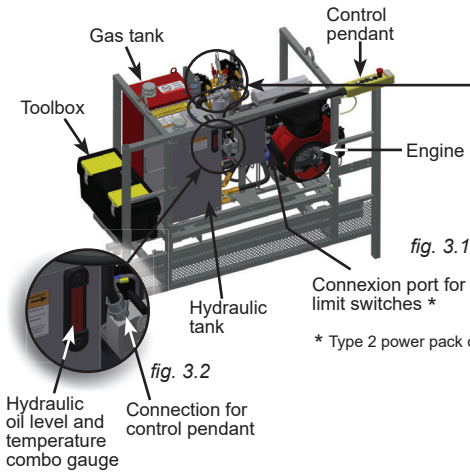

A	Hydraulic drain
B	Winch travel (UP - DOWN)
C	
D	Trolley travel (FRONT - BACK)
E	

Type 3 and type 4 power packs (current generation)

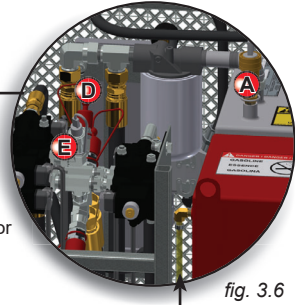
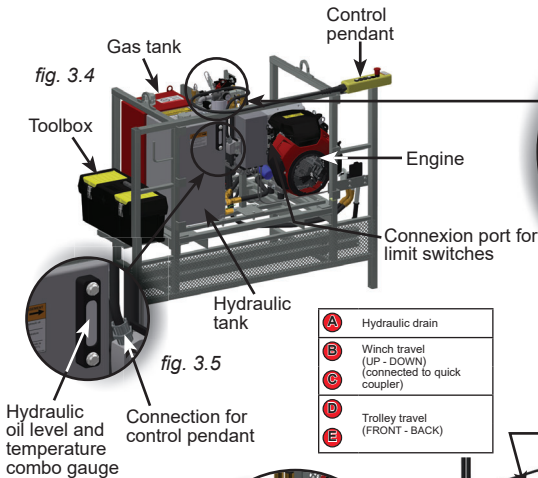

A	Hydraulic drain
E	Winch travel (UP - DOWN) (connected to quick coupler)
C	
D	Trolley travel (FRONT - BACK)
E	

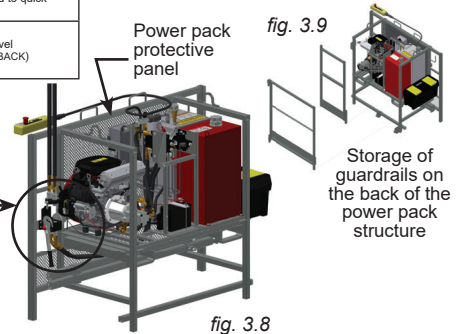
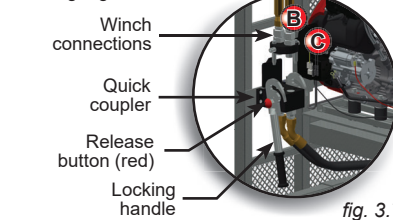
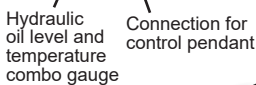

Power Pack and Components

Startup preparation instructions

- 1- Make sure that the hoist system has been installed following the installation instructions starting on p. 20 of the *Hoist* section and that it can be operated safely.
- 2- Remove the power pack protective panel (fig. 3.8, p. 25). If the hoist system is used on a 14' (4,3 m) motorized unit, make sure that the guardrail on the unit is present.

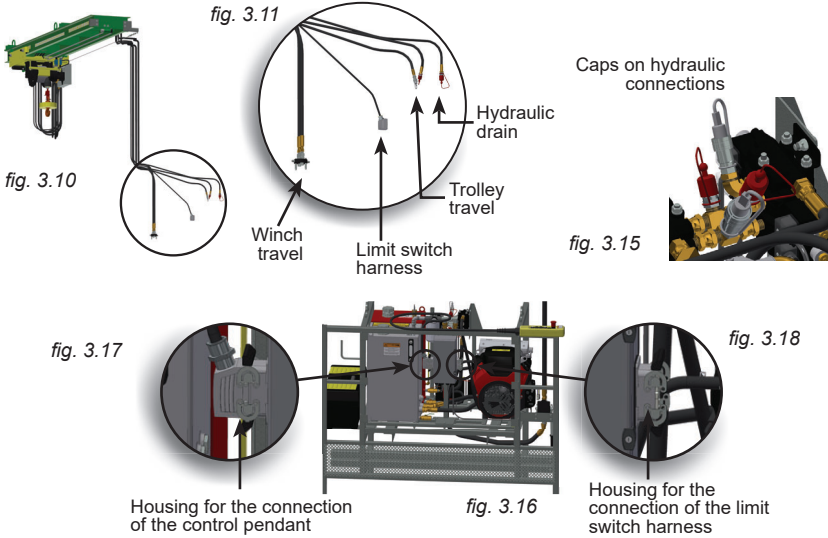

- 3- Remove the protective caps on all hydraulic connections.
- 4- Connect all hydraulic hoses, making sure that they have no kinks and are routed properly (see fig. 3.3 and fig. 3.6, p. 25, and fig. 3.11, p. 26).
- 5- Remove the protective cover on the connection housing for the control pendant and the limit switch harness (type 2 power packs and up).
- 6- Connect the control pendant and the limit switch harness.
- 7- Check the hydraulic oil level to make sure it is in the FULL range. If necessary, replenish with hydraulic oil. It is important to use a hydraulic oil recommended by Hydro Mobile.

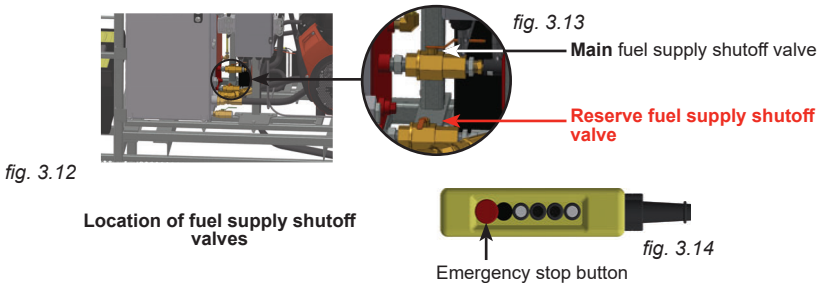

WARNING
It is important to make sure that the **reserve** fuel supply shutoff valve is **closed** during normal operation.

Power Pack and Components

Startup preparation instructions (cont'd)

- 8- Check the gasoline level and refill if necessary (fig. 3.6, p. 25).
- 9- Turn the **main** fuel supply shutoff valve (top) to the ON (operating) position, in line with the hose. Make sure the **reserve** shutoff valve (bottom) is **closed** (fig. 3.13, p. 26).
- 10- Check the engine oil level (fig. 3.4, p. 25). If necessary, refill in accordance with the specifications in the Honda engine user's manual.
- 11- Put the protective panel back into place.
- 12- Pull out the emergency stop button on the control pendant.

Engine startup instructions

- 1- Prepare the engine following the startup preparation instructions on p. 26.
- 2- Lift the throttle control lever at 3/4 of the way.
- 3- If the engine is cold, pull out the choke control.

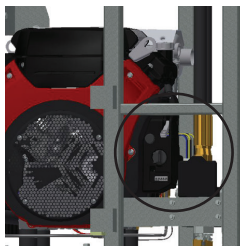

fig. 3.19

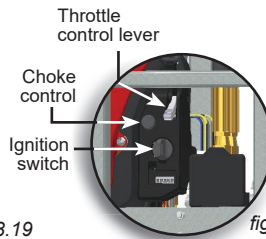

fig. 3.20

- 4- Turn and hold the ignition key until the engine starts (hold for no more than 10 seconds at a time).
- 5- Push in the choke control once the engine has started. In cold weather, leave the choke control out a little longer.
- 6- Lift up the throttle control lever all the way to reach maximum RPM. In cold weather, let the engine run at full throttle for a few minutes to warm up the hydraulic system.

Operation of the control pendant

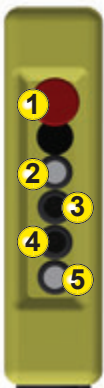

fig. 3.21

- 1- Make sure the emergency stop button is pulled out on the control pendant (see "1" in fig. 3.21).
- 2- Push in the UP button halfway to raise the load block at **first speed** (see "2" in fig. 3.21). To raise the load block at **second speed**, push in the UP button all the way.
- 3- Push in the DOWN button halfway to lower the load block at **first speed** (see "3" in fig. 3.21). To lower the load block at **second speed**, push in the DOWN button all the way.
- 4- Push in the FRONT button (see "4" in fig. 3.21) to move the trolley in toward the front of the unit (wall side). Release the button before the trolley reaches the end of the assembly.
- 5- Push in the BACK button (see "5" in fig. 3.21) to move the trolley out toward the rear (loading side) of the unit. Release the button before the trolley reaches the end of the assembly.

Power Pack and Components

Engine shutdown instructions

- 1- Lower the throttle control lever all the way down (idle position) and let the engine run at idle for about 30 seconds.
- 2- Turn the ignition switch to the OFF position to shut down the engine.
- 3- Turn the ignition switch to the ON position again (without starting the engine) and release the pressure from the hydraulic circuit, as described in the steps below.
- 4- Push in the emergency stop button.
- 5- At the end of the working shift or if the hoist will not be used for a significant length of time, turn the main fuel supply shutoff valve to the OFF position (perpendicular with the hose). Make sure that the reserve shutoff valve is also at the OFF position.
- 6- Before transporting or storing the hoist power pack assembly for a significant length of time, make sure that the battery is disconnected.

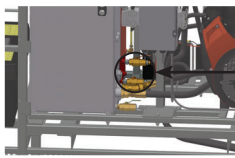

fig. 3.22

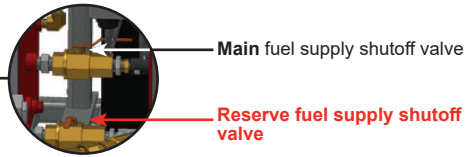

fig. 3.23

Releasing pressure from the hydraulic circuit

To prevent damages and facilitate the connection of hydraulic hoses, it is essential to bleed the pressure from the hydraulic circuit before disconnecting the hoses.

- 1- Make sure the **ignition switch at the ON position** but that the **engine is not running**.
- 2- Make sure that all the travel limit switches are plugged in and that none are triggered.
- 3- Make sure the emergency stop button on the control pendant is pulled OUT.
- 4- On the control pendant, **push in and hold each button for 5 seconds** to ensure that the pressure in the hydraulic lines is bled.

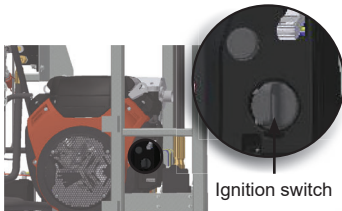
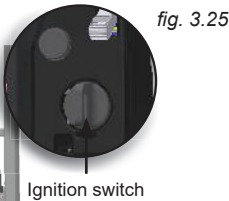

fig. 3.24



Ignition switch

fig. 3.28

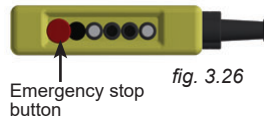

fig. 3.26

Emergency stop button

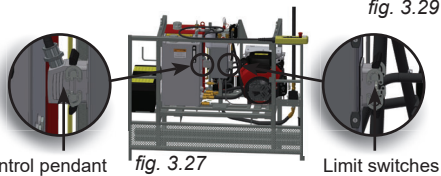

fig. 3.27

Control pendant

Limit switches

fig. 3.29

Preparation for removal of power pack

- 1- Disconnect all hydraulic hoses and secure them properly. Make sure that all protective caps are in place (fig. 3.15, p. 26).
- 2- Disconnect and store the control pendant. Put the protective cover back on the housing.
- 3- Disconnect the limit switch harness and secure it properly. Put the protective cover back on the housing.

Transport and Storage

The lift and relocation of a hoist system must be carried out with extreme care, using proper certified lifting equipment.

It is **mandatory** to refer to and comply with the capacities and limitations of the lifting device as specified by the manufacturer. It is important to consider the total weight that must be lifted. Refer to p. 14 of the *Hoist* section for the weight of the hoist structure and of the power pack assembly.

Lifting the hoist structure – using slings or chains (crane or forklift)

- 1- Slip chains or slings through the lifting lugs on top of the hoist structure. Secure the chains or slings to a crane or to the forks of a rough terrain forklift.
- 2- If a rough terrain forklift is used, make sure to use an appropriate forklift attachment to secure the chains or slings (shown in red in fig. 4.4).

Lifting the power pack – using slings or chains (crane or forklift)

- 1- Slip chains or slings through the lifting lugs on top of the power pack assembly. Secure the chains or slings to a crane or to the forks of a rough terrain forklift.
- 2- If a rough terrain forklift is used, make sure to use an appropriate forklift attachment to secure the chains or slings (shown in red in fig. 4.4).

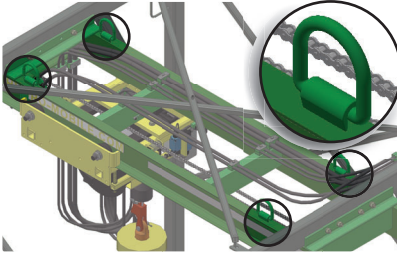

fig. 4.1

Location of lifting lugs on top of hoist structure

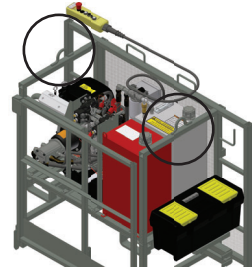

fig. 4.2

Location of lifting lugs on top of power pack assembly

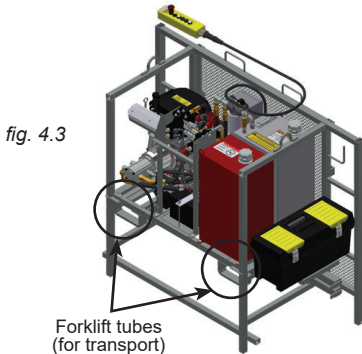

fig. 4.3

Forklift tubes (for transport)

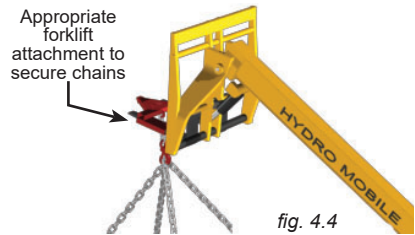

fig. 4.4

Appropriate forklift attachment to secure chains

Lifting the power pack – using forklift tubes (to transport power pack only)

This method is used to transport the power pack from one location to another. It is recommended to lift the power pack by the lifting lugs when installing.

- 1- Insert the forks of a rough terrain forklift in the forklift tubes on the power pack (fig. 4.3).
- 2- Carefully lift and carry the power pack to the desired location. Lower the power pack in place.

Transport and Storage

Storage of the hoist

- 1- Make sure that the hoist has been dismantled properly, as described in the dismantling instructions on p. 23 of the *Hoist* section.
- 2- Inspect the structure of the hoist for any sign of damage or distortion. Clean the hoist thoroughly to limit the effects of any corrosive agent.
- 3- Lubricate the outer layer of the wire rope to prevent rust and corrosion.
- 4- Before storing the hoist, make sure to place sufficient cribbing under it to prevent damages to the bottom of the structure.
- 5- Make sure that each quick connect fitting is covered with a protective cap and that all hydraulic hoses are routed properly, without any kinks.
- 6- Choose an appropriate storage location. Avoid storing the hoist in a location with direct exposure to aggressive or corrosive materials in the surroundings.

Storage of the power pack assembly

- 1- Make sure that the power pack has been dismantled properly, as described in the dismantling instructions on p. 28 of the *Hoist* section. Make sure that all hydraulic pressure has been removed from the hydraulic hoses. For instructions on the release of pressure in the hydraulic circuit, refer to p. 28 of this section.
- 2- Before storing the hoist power pack assembly for a significant length of time, make sure that the battery is disconnected.
- 3- Make sure that each quick connect fitting is covered with a protective cap.
- 4- Inspect the structure of the rack for any sign of damage or distortion. Clean the rack thoroughly to limit the effects of any corrosive agent.
- 5- Before storing the power pack, make sure to place sufficient cribbing under it to prevent damages to the bottom of the structure.
- 6- Choose an appropriate storage location. Avoid storing the power pack in a location with direct exposure to aggressive or corrosive materials in the surroundings.

Inspections and Maintenance

Proper maintenance and service will warrant safe and trouble-free operation of a hoist system. In order to ensure operational safety and avoid failures, the owner and/or user must make sure that all the scheduled inspection and maintenance operations have been effectively and timely carried out according to the inspection and maintenance schedules for hoist systems.

Blank copies of the daily inspection checklist must be available on job sites at all times to be filled out when daily and weekly inspection operations are carried out. Maintenance and inspection logs must be kept on record for warranty and safety purposes.

Copies of all maintenance and inspection checklists can be obtained by contacting the distributor/service center or downloaded directly from the Hydro Mobile website at www.hydro-mobile.com.

Inspection of the wire rope

- 1- Inspect the wire rope to make sure that it is in proper condition. Typical damages to the wire rope include broken wire, kinked wire, worn wire, corrosion, heat damage and birdcaging. Refer to local regulations regarding the inspection of the wire rope.
- 2- Any repair or change to the wire rope must be performed by a qualified technician. For more information about a qualified technician, refer to p. 7 of the *Performance and Safety* section.

fig. 4.5

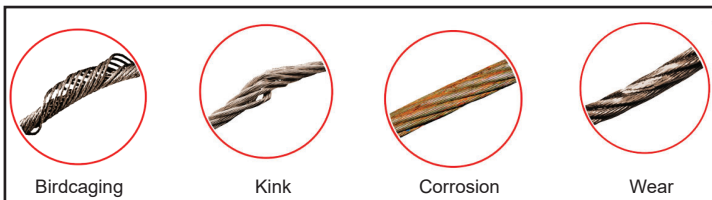

Inspections and Maintenance

Lubrication of the wire rope

The wire rope must be lubricated with a wire rope lubricant, according to the maintenance schedule.

- 1- Make sure that the wire rope is clean.
- 2- Lubricate the wire rope properly.

Inspection of the hook

- 1- Inspect the hook and make sure it is in good condition and is not bent in any way.
- 2- Make sure that the latch of the hook is in place and operates properly.

Inspection of the wedge socket

- 1- Inspect the wedge socket and make sure the routing is appropriate, as shown in fig. 4.6. Any change to the routing of the wire rope must be performed by a qualified technician. For more information about a qualified technician, refer to p. 7 of the *Performance and Safety* section.

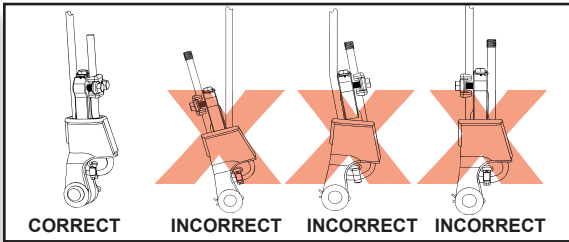

fig. 4.6

Greasing of the traverse chain rollers and the pivot points

- 1- Grease each of the pivot points shown in the images below.
- 2- Each pivot point must be greased according to maintenance schedule, using Prolab GS 1000 grease. Pivot points are located as shown in the images below, two on the trolley structure and one at the end of the beam assembly.

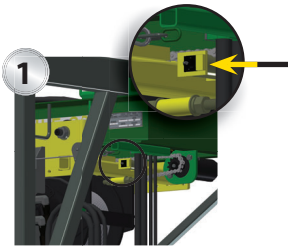

fig. 4.8

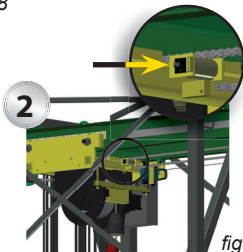
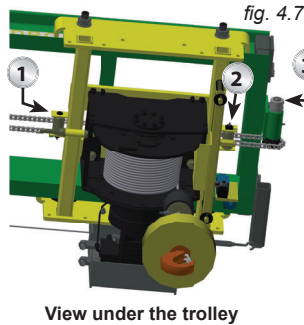

fig. 4.9

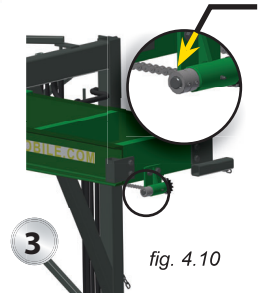

fig. 4.10

Inspections and Maintenance

Daily and Weekly Inspections and Maintenance

Daily and weekly inspections must be performed by a qualified operator. For more information about qualified operator, refer to p. 7 of the *Performance and Safety* section.

Each Hydro Mobile hoist system must be submitted to **daily (or before every working shift)** and weekly inspections and maintenance operations performed by the qualified user/operator. For more information about a qualified user/operator, refer to p. 7 of the *Performance and Safety* section.

Daily and weekly inspection operations are only necessary when the hoist system is in use. The owner and/or user is responsible for all inspection and maintenance operations. Before being first used on a job site, a hoist system must be inspected effectively and timely, according to the schedules for hoist systems.

Maintenance and inspection logs must be kept on record for warranty and safety purposes. Blank copies of the daily inspection checklist must be available on job sites at all times to be filled out when daily and weekly inspection operations are carried out. The notes and comments form must be used to indicate any discrepancy or any item found to be not acceptable. Any discrepancy must be reported to the competent person and appropriate corrective action must be taken immediately. Corrective actions must be performed by qualified personnel.

Frequent Inspections and Maintenance

Frequent inspections must be performed by a qualified technician. For more information about qualified technicians, refer to p. 7 of the *Performance and Safety* section.

Each Hydro Mobile hoist system must be submitted to a frequent inspection performed **every three months** by a qualified technician.

Maintenance and inspection logs must be kept on record for warranty and safety purposes. Blank copies of the frequent inspection checklist must be filled out when frequent inspection operations are carried out. The notes and comments form must be used to indicate any discrepancy or any item found to be not acceptable. Any discrepancy must be reported to the competent person and appropriate corrective action must be taken immediately. Corrective actions must be performed by a qualified technician. For more information about qualified technicians, refer to p. 7 of the *Performance and Safety* section.

All inspection and maintenance steps included in the daily inspection checklist must be performed before the frequent inspection and maintenance steps.

It is recommended to use replacement parts manufactured by or recommended by Hydro Mobile. The use of substitute parts could not only void the warranty covering this hoist system and its components but cause serious damages that could lead to injury or death. It is recommended to replenish and grease components only with fluids and lubricants recommended by Hydro Mobile.

Inspections and Maintenance

Annual Inspections and Maintenance

Annual inspections must be performed by a qualified technician. For more information about qualified technicians, refer to p. 7 of the *Performance and Safety* section.

Each Hydro Mobile hoist must be submitted to an annual inspection performed by a qualified technician. This annual inspection must be carried out **no later than 13 months after the previous annual inspection.**

Maintenance and inspection logs must be kept on record for warranty and safety purposes. Blank copies of the annual inspection checklist must be filled out when annual inspection operations are carried out. The notes and comments form must be used to indicate any discrepancy or any item found to be not acceptable. Any discrepancy must be reported to the competent person and appropriate corrective action must be taken immediately. Corrective actions must be performed by a qualified technician. For more information about qualified technicians, refer to p. 7 of the *Performance and Safety* section.

It is recommended to use replacement parts manufactured by or recommended by Hydro Mobile. The use of substitute parts could not only void the warranty covering this hoist system and its components but cause serious damages that could lead to injury or death. It is recommended to replenish and grease components only with fluids and lubricants recommended by Hydro Mobile.

Inspections and Maintenance

Samples of Checklists

Copies of the inspection and maintenance checklist shown below can be obtained by contacting the distributor/service center or downloaded directly from the Hydro Mobile website at www.hydro-mobile.com.

Daily inspection checklist

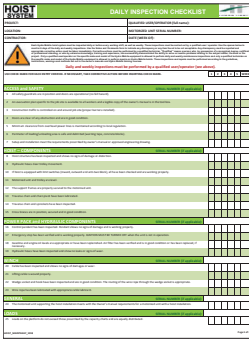

The 'Daily inspection checklist' form includes a header with the HOIST logo and a title. It features a warning icon and a section for 'Pre-Operation Checks' with a grid for recording results. Below this, there are several sections for 'Operational Checks' and 'Post-Operation Checks', each with a grid for recording observations and actions. The form is designed for quick data entry during daily operations.

fig. 4.12

Frequent inspection checklist

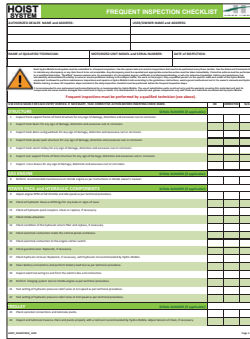

The 'Frequent inspection checklist' form is similar in layout to the daily checklist but includes a 'Pre-Operation Checks' section with a warning icon. It contains multiple sections for 'Operational Checks' and 'Post-Operation Checks', each with a grid for recording data. The form is intended for more thorough inspections performed frequently.

fig. 4.13

Annual inspection checklist

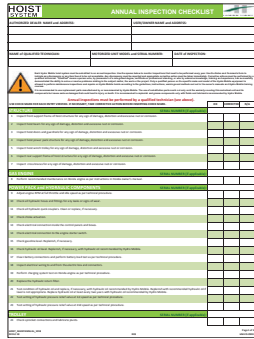

The 'Annual inspection checklist' form includes a header with the HOIST logo and a title. It features a warning icon and a section for 'Pre-Operation Checks'. Below this, there are several sections for 'Operational Checks' and 'Post-Operation Checks', each with a grid for recording results. The form is designed for comprehensive annual inspections.

fig. 4.11

Copies of the job survey checklist and the handover checklist shown below can be obtained by contacting the distributor/service center or the Hydro Mobile technical support team or downloaded directly from the Hydro Mobile website at www.hydro-mobile.com.

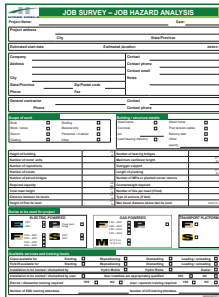

The 'JOB SURVEY - JOB HAZARD ANALYSIS' form is a detailed document for assessing job risks. It includes a header with the HOIST logo and a title. The form contains several sections for 'Job Information', 'Hazard Identification', and 'Risk Assessment'. It features a grid for recording hazards and their associated risks, along with a section for 'Control Measures'. The form is designed for thorough job hazard analysis.

fig. 4.14



The 'INSTALLATION HANDOVER SHEET' form is a document for transferring information between different teams or individuals. It includes a header with the HOIST logo and a title. The form contains several sections for 'Installation Details', 'Handover Information', and 'Signatures'. It features a grid for recording installation details and a section for 'Handover Information'. The form is designed for clear communication and record-keeping during installation handovers.

fig. 4.15